

PRZEDSIĘBIORSTWO DOSWIADCZALNO-PRODUKCYJNE
SZYBOWNICTWA "PZL-BIELSKO"

SZD-51-1 "JUNIOR" GLIDER

FLIGHT MANUAL

Issue I - December 1984

Reg. No

Fact. No

B-1840

This is the translation of Polish text
approved by Central Administration of Civil
Aviation

Translated by:

W. Stafiej D.Sc.

W. Stafiej

Issue I - December 1984

No inscriptions or supplements are allowed to be introduced to this Manual if not approved by the Authority.

In case this Manual has been lost the Authority shall be informed immediately. Everyone who finds this Manual is asked to mail it to the Ministry of Communication, Central Administration of Civil Aviation.

In this Manual the revisions contained in Bulletin No BE-001/85 "JUNIOR" have been introduced.

LIST OF REVISIONS

NOTE: Place where the text has been revised is marked with vertical line on the left side of text and with the item of revision.

Item	Page	REVISION	Date	Signature
1	7	Replaced with page 7A according to the Bulletin No BX-002/85 "JUNIOR"	85-07-15	<i>[Signature]</i>
2	7 A	Increased aileron hinges	87-03-05	
3	41	Introduction of modified rear fitting-version II	88-03-3	

Drawn: SW/PT checked: thals / 2000/ 46/92

Item	Page	REVISION	Date	Signature

SZD-51-1	FLIGHT MANUAL	Page:
		5
CONTENTS		
1. DESCRIPTION OF GLIDER		7
1.1. General description		7
1.2. Main technical data		9
1.3. Instrument installation		9
2. OPERATION LIMITATIONS		10
3. PERFORMANCES		14
4. OPERATION OF GLIDER		15
4.1. Pre-flight inspection		15
4.2. Operations before flying		15
4.3. Pilot in cockpit		18
4.4. Procedures before take off		20
4.5. Controlling		20
4.6. Operations after flights		26
4.7. Assembling and disassembling		26
4.8. Road transportation		27
4.9. Directions for Mc Cready ring ...		29
5. DANGER AND EMERGENCY CONDITIONS ...		30
5.1. Landing in high plantation		30
5.2. Break off or unintended releasing of towing cable		30
5.3. Emergency exit and use of parachute		30

SZD-51-1	FLIGHT MANUAL	Page:
		6
6. FIGURES		
Fig. 1. SZD-51-1 "JUNIOR" glider		33
Fig.2. Instrument installation		35
Fig.3. Mc Cready ring for SZD-51-1 glider		36
Fig.4. Speed polar for SZD-51-1 glider .		37
Fig.5. Wing assembling		39
Fig.6. Horizontal tailplane assembling ..		41
Fig.7. Colour marking of airspeed indicator dial		43
Fig.8. Adjustment of pilot's back rest and seat		45
Fig.9. Allowed range of empty glider c.g. location		47
Fig.10. Operation of elevator trimming		49
Fig.11. Displacement of placards		51
7. PLACARDS		
		50
8. TABLE OF GLIDER WEIGHING		
		57

SZD-51-1	FLIGHT MANUAL	Page: 8
<p>Adjustable air-conditioning, airflow directed on canopy front part and pilot's face.</p> <p>TAIL UNIT: "T"-arrangement. Rudder, stabilizer and elevator of glass-fibre structure. Elevator divided on two parts, each one suspended on three points. Both elevator halves are equipped with fixed glass-fibre tabs to increase the hinge moment. The rudder covered with fabric, mass-balanced, suspended on two points.</p> <p>EQUIPMENT: instruments /listed in item 1.3/ sanitary installation and first-aid kit. The aerial incorporated into fin structure to enable the use of transceiver.</p> <p>HOOKS: The glider is equipped with front and bottom hooks in one of the following combinations /acc.to user's order/:</p> <p>a/ Both hooks of SZD-III A 56c type without the self-releasing mechanism, or</p> <p>b/ Front hook of TOST E72 type without the self-releasing mechanism and bottom hook of TOST G72 type with the self-releasing mechanism.</p> <p>The kind and type of hook is related on the placard in cockpit. The hooks are accessible from cockpit: the front one - when the instrument panel and its column are removed, the bottom one - when the seat pan is removed.</p> <p>Both hooks are released by means of pulling the common control hand-grip. When the hand-grip is released the hooks are closed due to the return spring action.</p> <p>When winch-launched using the bottom hook of TOST type with self-releasing mechanism</p>		
Issue I - Dec. 1984		

SZD-51-1	FLIGHT MANUAL	Page: 7 A
<p>1. DESCRIPTION OF GLIDER</p> <p>1.1. General description</p> <p>SZD-51-1 "JUNIOR" is the school and training one-seater built on base of JAR-22 Requirements in "U" category. Glass-fibre/epoxy structure.</p> <p>WING - in two panels of double-trapez planform Double T spar with longerons and web of glass-fibre composite. Sandwich coverings glass-fibre /foam/glass-fibre. Rear web of glass-fibre, ribless structure.</p> <p>AILERON: undivided at 20 % of chord, mass balance, suspended on 5 points, actuated in one point. Glass-fibre structure.</p> <p>AIR BRAKE: Plates of duraluminium sheet extended on upper surface only, equipped with caps fitted to wing contour.</p> <p>FUSELAGE integral with fin, glass-fibre structure. The central part comprises the steel framework to which the wings and undercarriage are attached.</p> <p>UNDERCARRIAGE: fixed, no shock absorber. Wheel of Ø 400x140 size with disc brake. Tube pressure of 0,15 MPa Fixed rear wheel of Ø 200 diameter. The wheel brake and air brake controls are independent.</p> <p>COCKPIT covered with one-piece canopy side opened. Nearly sitting pilot's position, adjusted on ground by means of folded pillow. Pedals adjusted in flight. Instrument panel supported on column.</p>		
Issue I - Dec. 1984		

SZD-51-1	FLIGHT MANUAL	Page: 9																				
<p>the glider releases the cable automatically when the cable reaches the maximum release angle.</p> <p>MOVABLE EQUIPMENT: assembling lever, screwdriver, wrench for wheel brake adjustment canvas cover for canopy.</p> <p>1.2. Main technical data</p> <table border="0"> <tr><td>Span</td><td>15,00 m</td></tr> <tr><td>Length</td><td>6,69 m</td></tr> <tr><td>Height</td><td>1,57 m</td></tr> <tr><td>Dihedral of wing</td><td>3°</td></tr> <tr><td>Wing area</td><td>12,51 m²</td></tr> <tr><td>Aspect ratio</td><td>18</td></tr> <tr><td>Root chord</td><td>1,115 m</td></tr> <tr><td>Mean Standard Chord</td><td>0,88 m</td></tr> </table> <p>Wing section: Wortmann S02-196 // S02/1-158 Mass of empty glider with standard equipment is 441 + 529,2 lb see Fig.9</p> <table border="0"> <tr><td>All-up mass</td><td>837,9 lb</td></tr> <tr><td>Minimum wing mass</td><td>231,5 lb</td></tr> </table> <p>1.3. Instrument installation /Fig.2/</p> <p>The installation comprises:</p> <ul style="list-style-type: none"> - instrument panel, - total pressure head located at fuselage nose, - 2 static pressure ports located on front fuselage part. 			Span	15,00 m	Length	6,69 m	Height	1,57 m	Dihedral of wing	3°	Wing area	12,51 m ²	Aspect ratio	18	Root chord	1,115 m	Mean Standard Chord	0,88 m	All-up mass	837,9 lb	Minimum wing mass	231,5 lb
Span	15,00 m																					
Length	6,69 m																					
Height	1,57 m																					
Dihedral of wing	3°																					
Wing area	12,51 m ²																					
Aspect ratio	18																					
Root chord	1,115 m																					
Mean Standard Chord	0,88 m																					
All-up mass	837,9 lb																					
Minimum wing mass	231,5 lb																					
Issue I - Dec. 1984																						

SZD-51-1	FLIGHT MANUAL	Page: 10														
<ul style="list-style-type: none"> - ducts, drainage units and four-way connector, - nest for the additional pressure head on the fin. <p>The instrument panel is attached to its column by means of screw located in face wall of panel and shielded on top with the cover fixed to the cockpit board.</p> <p>The "standard" equipment comprises the following instruments:</p> <ul style="list-style-type: none"> - airspeed indicator PR-250-S - altimeter W-10S or W-12S - variometer WRS-5D with KWEC-2 compensator and bottle - slip and turn indicator EZS-3 - Compass BS-1 <p>The place for installation of special instruments provided on instrument panel and on its column.</p> <p>2. OPERATION LIMITATIONS</p> <table border="0"> <tr><td>1. Maximum permissible mass of empty glider with standard equipment</td><td>529,2 lb</td></tr> <tr><td>2. Permissible loading mass:</td><td>308,7 lb</td></tr> <tr><td> where: minimum cockpit load</td><td>121,3 lb</td></tr> <tr><td> maximum cockpit load</td><td>242,6 lb</td></tr> <tr><td>3. Maximum all-up mass</td><td>837,9 lb</td></tr> <tr><td>4. Limit load factor</td><td>+5,3g; -2,65 g</td></tr> <tr><td>5. Ultimate load factor</td><td>+7,95g; -3,97g</td></tr> </table>			1. Maximum permissible mass of empty glider with standard equipment	529,2 lb	2. Permissible loading mass:	308,7 lb	where: minimum cockpit load	121,3 lb	maximum cockpit load	242,6 lb	3. Maximum all-up mass	837,9 lb	4. Limit load factor	+5,3g; -2,65 g	5. Ultimate load factor	+7,95g; -3,97g
1. Maximum permissible mass of empty glider with standard equipment	529,2 lb															
2. Permissible loading mass:	308,7 lb															
where: minimum cockpit load	121,3 lb															
maximum cockpit load	242,6 lb															
3. Maximum all-up mass	837,9 lb															
4. Limit load factor	+5,3g; -2,65 g															
5. Ultimate load factor	+7,95g; -3,97g															
Issue I - Dec. 1984																

6. Distance of c.g of empty glider with standard equipment aft of wing root leading edge /glider in attitude acc.to item 6 of Technical Service Manual/ } see Figs

7. Allowable range of c.g. location in flight referred to Mean Standard Chord 22,7 to 44,9 per cent of Mean Standard Chord

8. Loading plan
Correct value and location of load masses is listed on LOADING PLAN placard /see page 53/.

N O T E S:

1. The location of balancing mass B in instrument panel for pilots of mass below 125,7 lb is not obligatory, when the glider is equipped with RS-6101 transceiver or TA-03A oxygen equipment or additional equipment of mass more than 2,2 lb in instrument panel.

2. In case the oxygen bottle is installed on the framework of central fuselage part /acc.to Annex No 2 to this Manual/ the maximum allowable additional loading mass B in instrument panel is 11 lb in the full range of pilot's mass up to 242,6 lb

3. Installation of load E other than oxygen bottle of TA-03A equipment on the central fuselage part framework should be accepted by the Authority.

4. When flying without the parachute the additional back-cushion of min 9 cm thickness /when pressed/ should be used.

5. In case the glider is loaded in way other than stated in Loading Plan /e.g for pilot's mass other than allowable cockpit mass/ the mass value of all-up glider and c.g. location shall be defined by weighing the glider with full load.

9. Flight limitations IAS airspeeds knots

- a/ Take-off and aerotowed flight up to $V_T = 81$ knots
- b/ Winch - launching with airspeed up to $V_W = 70,2$ knots
- c/ Diving with airspeed:
 - in smooth air $V_{NE} = 118,8$ knots
 - in gust conditions $V_B = 83,7$ knots
- d/ Extending of and flight with airbrake extended
 - in smooth air $V_{NE} = 118,8$ knots
 - in gust conditions $V_B = 83,7$ knots
- e/ Manoeuvring airspeeds
 - up to $V_A = 83,7$ knots
- f/ Maximum load factor:
 - $n_A = +5,3$ g at airspeed .. $V_A = 83,7$ knots
- g/ Maximum load factor:
 - $n_D = +4,2$ g at airspeed .. $V_{NE} = 118,8$ knots

- h/ Aerobatic manoeuvres:
 - looping
 - stall turn
 - quick half-roll-half-loop
 - spiral
 - spinning
- i/ Altitude flying allowed providing that the glider is equipped with efficient oxygen equipment.
- j/ Bungy take-off allowed.
- 10. Restrictions:
 - The glider is not allowed for:
 - night flying
 - winch - launching on front hook
- 11. Additional statements:
 - a/ When aerotowing the cable safety link of 690± 10 % daN shall be used /Standard: BN-65/3833-45/
 - b/ Before the first flight the pilot should be familiar with Flight Manual.
 - c/ When towed, the flight below the airplane level is not recommended since the cable contacts the fuselage surface.
 - d/ Flying in ice-condition should be limited only to unavaoided cases.
 - e/ At $V_{NE} = 118,8$ knots airspeed the rudder and aileron deflection is allowed as 1/3 of full deflection. The small gentle elevator deflections are allowed.

f/ At $V_A = 83,7$ knots airspeed the full control surfaces deflection is allowed.

3. PERFORMANCES: /fig. 4/

		GLIDER		
All all-up mass of	573,3 lb	734,3 lb	837,9 lb	
At mass loading of	4,3 lb/ft ²	5,5 lb/ft ²	6,2 lb/ft ²	
Minimum sinking speed	105ft/min	112,7ft/min	124,4ft/min	
at airspeed of ..	33,5knots	37,8 knots	41,8 knots	
Maximum L/U	35	35	35	
at airspeed of ..	37,8knots	43,2 knots	45,9 knots	
Sinking speeds at airspeeds	ft/min	ft/min	ft/min	
Of V knots				
54,0	209,9	186,6	175,0	
59,4	254,7	225,5	210,0	
64,8	305,2	266,3	248,8	
70,2	371,3	311,0	291,6	
75,6	447,1	365,5	340,2	
81,0	534,6	431,6	398,5	
86,4	630,0	519,0	470,4	
91,8	734,8	606,5	548,2	
97,2	882,6	699,8	631,8	

4. OPERATION OF GLIDER

4.1. Pre-flight inspection

Before the flights it shall be inspected:

- integrity of structure and coverings,
- securing of assembling elements and control system joints,
- operation of control systems,
- operation of hooks /front and bottom, if installed/.
- undercarriage condition, rollability of main and tail wheels, operation of wheel brake,
- air pressure in tube and tyre, cleanness of undercarriage housing,
- pilot's safety belts,
- total and static pressure ports /clean if necessary/.
- operation of instruments.

4.2. Operations before flying

4.2.1. Opening and locking of the canopy

The Canopy is side opened and fixed on two hinges at right board. In emergency the hinges are released when the emergency jettisoning levers are moved forwards /red ball at right side/. On left side opposite to emergency jettisoning lever is situated the canopy locking lever accessible from outside through the window.

4.2.2. Inserting of towing cable

- /1/ Pull the releasing grip full.
 - /2/ Insert the small ring of cable end into the hook and release the grip,
 - /3/ CHECK THE CORRECT CABLE LOCKING PULLING IT SEVERAL TIMES !
- Two hooks can be installed on the glider /see page: 8/.

4.2.3. Transportation on airfield

The glider with locked canopy can be towed by motor-car or tractor with speed up to 5,4 knots. The towing rope not shorter than 4 m.

NOTE: THE MANOEUVRING WITH GLIDER ON MUD STICKY GROUND ESPECIALLY BACKWARDS MAY CAUSE THE MUD TO JAM THE TYRE TO FENDER AND RESTRICT THE WHEEL ROLLABILITY.
CLEAN BEFORE TAKE-OFF !

4.2.4. Anchoring of glider

1. Put the glider into position to have the side-back wind
2. Anchor the glider on the following points:
/wing: the wing tip directed toward wind should be supported on 30-50 cm height, wrap with seat-cushion and attache with anchoring cord to the picket or anchor-rod in distance of about 50 cm from wing tip.

FAKOPET Bratislava 1984 800 001 01

Fuselage: Fix the tail part to the pickets or anchor-rods sticked to ground on both sides.
Wrap the fuselage tube near the fin with anchoring cord. Avoid the contact of pickets with fuselage surface. Anchor the fuselage front part by means of front or bottom hook.
The aileron and elevator shall be immobilized by means of right pilot's back belt joined with right abdomen belt on the control stick hand grip.

Rudder: should be immobilized by means of clamp /for fin and rudder/ made of two wooden slats joined on ends.

Air - brake: should be extended and secured by means of immobilizing the hand grip in cockpit using the left pilot's back-belt.

4.2.5. Procedures with wetted glider

In respect to structure /glass-fibre/ the glider is moisture and meteorological influences resistant. In case of heavy wetting e.g. landing on water or long standing on field when country landed, the structure inside should be ventilated by means of opening the inspection holes, canopy and extending the air brake. When dried the glider should be wiped with a flannel.

4.2.6. Drainaging of instrument pneumatic installation

After flight in prolonged rain /or in cloud/ it is necessary to:

1. Dry the drainage units and remove the drain plugs.

/2/ Disconnect the ducts of total and static pressure out of the instruments.

/3/ Blow through, if necessary, the ducts of total and static pressure heads /by means of pump for inflating the wheel tube/.

NOTE: BEFORE BLOWING THE DUCTS BE SURE THAT THE INSTRUMENTS ARE CORRECTLY DISCONNECTED OUT OF THE BLOWED PART OF INSTALLATION - THE DANGER OF INSTRUMENT DAMAGE.

/4/ Screw in the drainage unit plug, connect the installation and check the tightness.

4.2.7. Slip and turn indicator supply- inserting of batteries

Electric slip and turn indicator is supplied with direct current of 4,5 V taken from three round batteries of R20 type. The batteries are contained in round housing which is inserted into the bracket on right side of instrument panel.

NOTE: THE NEGATIVE POLE OF THE BATTERY SET SHALL BE DIRECTED AHEAD !

NOTE: THE USED BATTERIES SHALL NOT BE LEFT IN THE NEST !

4.3. Pilot in cockpit

The cockpit allows for pilots up to 1,95 m of height with back parachute. To adjust to pilot's position the glider is equipped with two part folded cushion

of various thickness. The different position of the pillow on seat or back-rest acc. to Fig. 8 ensures the multi-step adjustment of sitting position. For extremely high pilot the folded cushion is stored behind pilot's back-rest. The pilot's position should be adjusted so, to allow for easy access to hook releasing handle and all control levers. When flying without a parachute the additional cushion of thickness no less than 9 cm in pressed condition should be used. Upholstering the seat pan with rubber avoids the back-slip of pilot when winch-launched. The pedals are adjusted in flight /5 locations/. Pulling on the brown hand-grip /at right side of instrument panel column/ the pedals can be moved back or when pressed with both legs can be moved forwards.

When the leg force is released the latch locks the pedals in selected location.

The control systems of control surfaces and air brake are operated conventionally. The wheel brake lever is located on air brake control lever.

The spring trimming device is actuated by means of hand-grip on the left board. Operation of this device acc. to Fig. 10 is the following:

- Press the hand-grip /release the locking/ and put into the desired location, than LOCK /pull upwards/.

The canopy opens when the left lock is released /red hand grip put forwards/. In full opened position the canopy is retained by means of limiting cable.

4.4. Procedures before take-off

- /1/ Check the completion of ^{board} equipment /glider log-book, Flight Manual tools, anchoring facilities, covers, rope for ground towing/.
- /2/ Check the parachute rubber tension members and put the parachute on back.
- /3/ Adjust the cushion and take place in the cockpit, adjust the pedals and fasten the safety belts.
- /4/ Check the full movements of control surfaces and air brake. Adjust the trimming spring handle on position from "6" /for light pilot/ to "8" /for heavy pilot/ counting from front. For winch launching from "6" to "8" respectively.
- /5/ Check the operation of slip and turn indicator.
- /6/ Close the canopy and check the good locking.

4.5. Controlling

In school-flight the long towing cable should be used /minimum 40 m/. Before take-off adjust the trimming spring handle into position from "6" /light pilot/ to "8" /heavy pilot/ counting from front. During ground run till to airborning control the glider to roll on the main wheel. The recommended aero-towing airspeed when climbing is no less than 54 knots.

SZD-51-1	FLIGHT MANUAL	Page: 21
<p>4.5.2. <u>Winch-launching</u> - USE BOTTOM HOOK ONLY !</p> <p>Prior to connection check the cable position. The cable should lay a slight bow line at left - NOT RIGHT ! - side of take-off axis. The trimming device put into position "6" /light pilot/ to "8" /heavy pilot/.</p> <p>The take-off is correct and easy. In steep climbing the stick forces are low. The best launching airspeed ranges 51,3+56,7 knots</p> <p>To get the maximum altitude at the end of climb path the stick should be pulled slightly. The forces are low even for incorrect trimming.</p> <p>Before releasing it is recommended to ease the launching cable tension pushing the stick forwards.</p> <p>In case of intended self-releasing /for TOST EUROPA G72 hook only/ the stick position should be retained till the self-releasing occurs.</p> <p>When released the glider should be immediately introduced into normal glide and the cable releasing handle pulled once more for safety reason.</p> <p>The longer the launching cable the higher altitude gained. For cable of 700 m length and for winch of 200 PS power the releasing altitude at windless condition is 250 to 280 m.</p> <p>4.5.3. <u>Stalling</u></p> <p>In straight flight the glider stalls only with light pilot 121,3 + 154,3 lb fuselage nose in above horizon position and considerable pulling movement of the stick.</p>		
Issue I - Dec. 1984		

SZD-51-1	FLIGHT MANUAL	Page: 22
<p>The stalling is warned by means of fuselage vibrations. At the airspeed of 29,7 knots the glider drops down. If necessary the wing drooping can be avoided using the aileron. Recovery follows when the stick is moved forwards. The height loss is lower than 30 m.</p> <p>In the flight with average 154,3 + 198,5 lb and heavy 198,5 + 242,6 lb pilots the fuselage vibrations appear at about 37,8 knots</p> <p>The flight with stick full back is possible at about 36,7 knots if speed without dropping down.</p> <p>The stalling in circling is possible also with light pilot. Fuselage vibrations appear similar as in straight flight. When dropping the glider increases its bank.</p> <p>Recovery follows when the stick is moved forwards. The height loss is lower than 30 m.</p> <p>In flight with average and heavy pilot the glider can circle with the stick full back, without nose drooping.</p> <p>NOTE: THE ABOVE AIRSPEEDS CONCERN THE DRY GLIDER WITH AIR BRAKE RETRACTED.</p> <p>THE RAIN, ICE, OR AIR BRAKE EXTENDED INCREASE THE STALLING SPEED !</p> <p>4.5.4. <u>Spinning</u></p> <p>For all allowable loading conditions the glider can be safely entered into the spinning and recovered. At the front c.g. location /pilot of 198,5 + 242,6 lb, the full control surfaces deflections are necessary to retain the glider in spinning /elevator, aileron and rudder deflected full towards</p>		
Issue I - Dec. 1984		

SZD-51-1	FLIGHT MANUAL			Page: 23
the rotation/. In other case the glider recovers automatically. The other spinning properties are listed in table.				
SPINNING PROPERTIES				
Pilot lb	121,3 + 154,3	154,3 + 198,5	198,5 + 242,6	
	1	2	3	4
c.g location	rear	average	front	
Way of entering	Enter stall and full deflection of elevator and rudder	Enter stall in bank. Full deflection of all control surfaces		
Recommended aileron deflection	towards the rotation or neutral	towards the rotation		
Longitudinal oscillations	up to 3 turns	without oscillations		
Possible: 1 turn 2 turns 5 and more turns	yes yes yes	yes yes no		
Recovery delay	1/2 to 3/4 of turn	up to 1/2 of turn	0	
Issue I - Dec. 1984				

SZD-51-1	FLIGHT MANUAL		Page: 24
SPINNING PEOPERTIES /CONT./			
Height loss in one turn is 70 to 100 m. Time for performing of one turn is 3 to 4 sec.			
Recovery method - normal manoeuvre acc. to JAR 22 ACJ 22.221 Requirements:			
<ol style="list-style-type: none"> 1. Deflect the rudder against the rotation. 2. Short break. 3. Release the stick forwards till the rotation stops. 4. Neutralize the rudder and recover the glider out of diving. 			
Airspeed at recovering is 75,6 + 86,4 knots			
4.5.5. <u>Circling and side-slip</u>			
<p>Depending on bank and all-up mass of glider the circling airspeed is 43,2 + 45,9 knots Time of bank reversal 450/450 is about 3,4 sec.</p> <p>The side-slip is entered at airspeed of 48,6 knots and more by means of banking the glider with simultaneous opposite deflection of rudder. The bank up to 30° allows to retain the direction of flight, for greater bank angle the glider enters the turn. Depending on bank angle the airspeed indications drop down till to zero.</p>			
4.5.6. <u>Air brake</u>			
<p>High efficiency of air brake ensures the wide range of approach angles. Extending and retracting of airbrake causes the unperceptible changes in pitch. The air brake can be operated in the whole allowable airspeed range /above 97,2 knots open gently/.</p>			
Issue I - Dec. 1984			

SZD-51-1	FLIGHT MANUAL	Page: 25
<p>In diving with air brake extended at 118,8 knots airspeed the flight path angle is greater than 45°.</p> <p><u>4.5.7. Aerobatics</u></p> <p>Before starting the manoeuvres the glider should be trimmed on 64,8 + 75,6 knots airspeed and locking of trimming device and air brake checked.</p> <p>The contents of luggage compartment and pockets in cockpit should be immobilized. The glider performs correctly and smoothly the following manoeuvres:</p> <p>loopings and stall-turns /entry airspeed of 89,1 + 94,5 knots/, spirals 59,4 + 64,8 knots, quick half-roll-half-loop 48,6 + 51,3 knots. Performing of these manoeuvres is the standard one.</p> <p><u>4.5.8. Landing</u></p> <p>Approach airspeed is 48,6 + 54 knots /yellow mark on airspeed indicator dial/. Approach angle should be adjusted with air brake. On the low altitudes the abrupt air brake extending should be avoided.</p> <p>Touch the ground on two points /main and tail wheels/. On ground run the wheel can be braked.</p> <p><u>4.5.9. First flight</u></p> <p>Before the first flight pilot should be familiar with operation limitations and other informations contained in this Flight Manual.</p> <p>It is recommended to make the first flight in thermics. The flight programm should comprise: circling, stalling in straight</p>		
Issue I - Dec. 1964		

SZD-51-1	FLIGHT MANUAL	Page: 26
<p>flight and turn, flight with increased airspeed / 54 + 108 knots, depending on altitude and weather conditions/ and operating of air brake /several times/.</p> <p><u>4.6. Operations after flights</u></p> <ol style="list-style-type: none"> 1. Switch-off the slip and turn indicator and all other electrical equipment 2. Drain the ducts of instrument installation if necessary, acc. to item 4.2.6 3. Clean the cockpit and whole glider 4. Make the inspection /as pre-flight one acc.to item 4.1./ 5. Put on the dry canvas covers ON DRY AND CLEAN GLIDER ONLY ! <p><u>4.7. Assembling and disassembling</u></p> <p><u>4.7.1. Tools</u></p> <p>Assembling lever</p> <p><u>4.7.2. Assembling of wings /Fig.5/</u></p> <ol style="list-style-type: none"> 1. Put the airbrake handle in cockpit into front position, put the stick into the plane of glider symmetry. 2. Retract the airbrake plates, put ailerons into neutral position. 3. Put together the right and left wing with fuselage. When inserting the wing arms /1/ the protruding pivots of spars and fuselage framework /3/ should enter the proper nests /4/ on the root ribs of wing. The connections of aileron and air brake control system should be rigged too. 		
Issue I - Dec. 1984		

4. Hitch the assembling lever /5/ onto the feet /6/ of spars and pull the wings towards fuselage finally.

5. Connect the wings with bolt /7/ and secure inserting the pin arm into the hole /8/ and close the safety pin /9/.

4.7.3. Disassembling of wings /Fig.5/

Disassembling requires the reversal sequence in respect to item 4.7.2. Take off the bolt /7/ and remove the wings.

4.7.4. Assembling of horizontal tailplane /Fig.6/

1. Handle of spring trimming in cockpit should be moved into its front location.

2. Put the tailplane /1/ on the fin.

3. Connect the end of push-rod /3/ with the lever /4/ of elevator.

4. Connect the fittings inserting the bolt /5/ into the hole in fin leading edge and secure it with safety pin /6/.

4.7.5. Disassembling of horizontal tailplane /Fig.6/

Disassembling requires the reversal sequence in respect to item 4.7.4. Remove the bolt /5/ disconnect the joint /3/ and take-off the tailplane..

4.8. Road transportation

To prepare the disassembled glider for road transportation it is necessary to:

1. Check the completion of glider part and equipment.

2. Immobilize the contents of the cockpit and luggage compartments.

3. Immobilize the stick by means of pilot's belts.

4. Immobilize the vertical push-rod of elevator control system.

5. Lock the ailerons and rudder /put on the fixators/

6. Close and lock the canopy, shut the window.

7. Put the dry canvas covers on the canopy, fuselage, wings, tail unit and secure against a dust the opened bearings of control systems, the assembling elements of wings and elevator /wrap with paraffined paper or rags/

When installed on a trailer the glider can be fixed on:

- external surfaces by means of wide clamps upholstered with soft material or by means of ribbons,

- wings on spar root-ends,

- fuselage on main and tail wheels.

4.9. Directions for McCready-Ring
Scale on calculation ring of variometer for SZD-51-1 glider.
Glider all-up mass 734,3 lbwing loading .5,5 lb/ft² /

Ring knots	Vario- meter ft/min	Average climbft/min	Inter- thermal knots	Cross- country knots
37,8	0,0	97,2	47	18,6
43,2	194,4	194,4	56,7	27,5
48,6	262,4	291,6	67,5	33,8
54	330,5	388,8	70,2	39,2
59,4	408,3	486	74	42,9
64,8	515,2	583,2	77	46,2
70,2	680,4	680,4	79,4	49,1
75,6	913,7	777,6	84,8	51,8
81	1166	874,8	89,1	54,3
86,4	1360	922,0	91,8	56,7
91,8	1574			

Parameters of cross-country flight in conditions without
air descending zones. /Glider all-up mass 734,3 lb wing
loading 5,5 lb/ft² /

FLIGHT MANUAL

SZD-51-1

Page: 29

Issue I - Dec. 1984

SZD-51-1	FLIGHT MANUAL	Page: 30
5.	DANGER AND EMERGENCY CONDITIONS	
5.1.	Landing in high plantation When landing in high corn or grass the glider is exposed on damage when hitches even slightly the wing and makes the ground-looping. In unavoiided cases the landing should be possibly precise. The plantation surface should be assumed as ground surface. On ground the main wheel should be braked.	
5.2.	Break-off or unintended releasing of towing cable When the cable breaks or is unintended released on low altitude it is necessary to 1. Release the hook /when the cable remained with glider/. 2. Fasten the back belts. 3. Select the place for landing. In case of unavoiided collision with an obstacle in field landing DO NOT ALLOW FOR FRONT CRASH !	
5.3.	Emergency exit and use of parachute The parachute exit is the only possibility of pilot's rescue if the glider cannot come to ground in an controlled manner, e.g. in case of: - fire or damage making the flight impossible - serious misdisposition of pilot /e.g. injured eyes/.	

Issue I - Dec. 1984

- lack of visibility due to the cloud covering ranging up to ground.

5.3.1. Procedures for emergency exit

- /1/ Let the stick free.
- /2/ Push forward up to stop the handles of canopy jettisoning and push the canopy upwards.
- /3/ Release the safety belts.
- /4/ Leave the cockpit towards axis of eventual rotation of glider.
- /5/ If the altitude allows delay the opening of parachute. On altitude below 200 m open the parachute immediately.

5.3.2. Procedures in special cases

- /1/ When the canopy cannot be jettisoned try to destroy the perspex beginning near the window, eventually help with legs.
 - /2/ In case the exit must be done on high altitude take into account:
 - a/ possibility of climbing on opened parachute /e.g. in cloud/ and the danger of lack of oxygen or icing of parachute,
 - b/ possibility of employ the oxygen equipment installed on glider,
 - c/ air temperature.
- Taking the above into account it may be recommended to stay inside the cockpit /if glider condition allows for/ to altitude of 4500 - 4000 m or even lower.

F I G U R E S

Fig. 1 SZD-51-1 "JUNIOR" glider

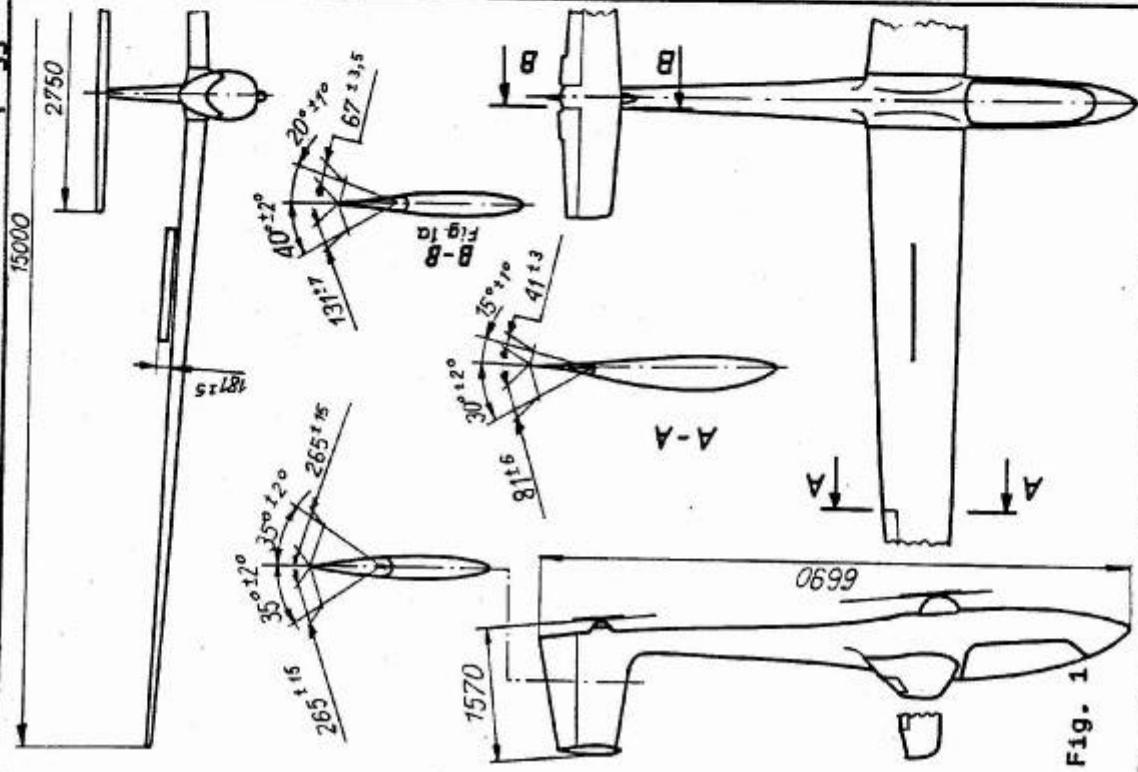

Fig. 1

Fig. 2. INSTRUMENT INSTALLATION

- 1 - airspeed indicator PR-250 S seria B
- 2 - altimeter W-10S /or W-12S/
- 3 - variometer WRs-5D with KWEC-2 compensator and McCreeedy ring
- 4 - compass BS-1 /or KI-13A/
- 5 - Slip and turn indicator EZS-3
- 6 - static pressure heads
- 7 - total pressure head
- 8 - drainage units
- 9 - duct connector
- 10 - Bottle
- 11 - instrument panel assembling screw
- 12 - instrument panel column
- 13 - electrical variometer x/
- 14 - nest of K--1 pressure head
- 15 - K--1 pressure head x/
- 16 - bottle x/

x/ Additional equipment

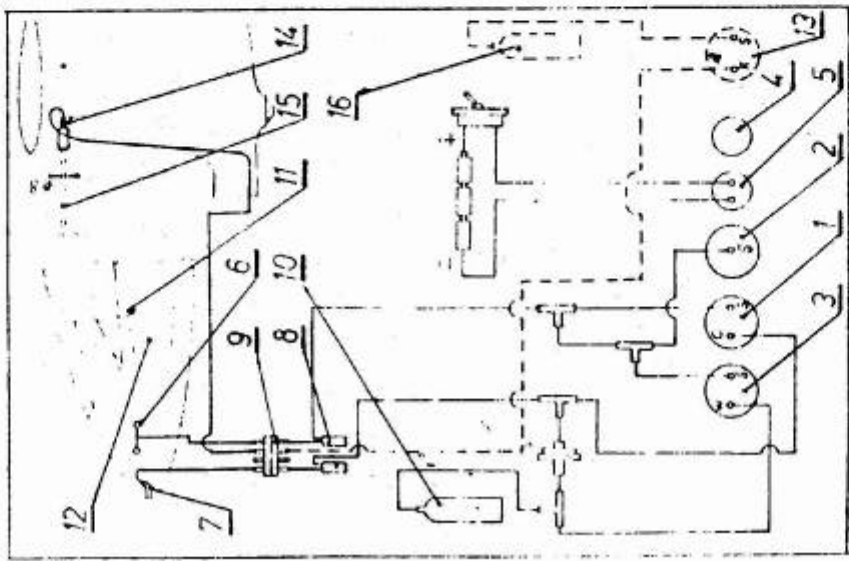

Fig. 2

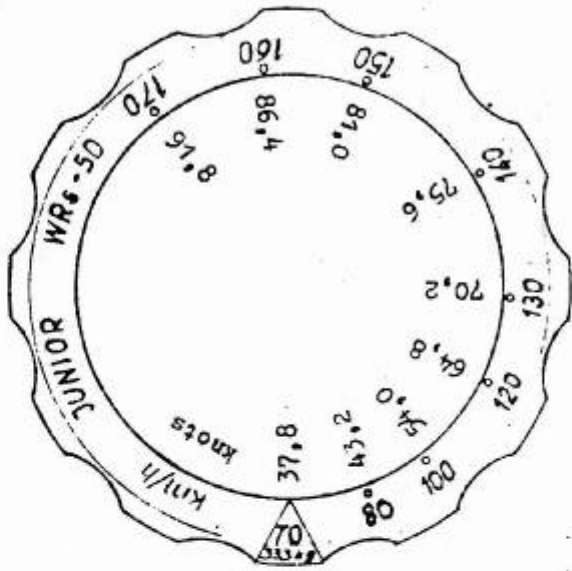

Fig. 3 Mc Cready ring for SZD-51-1 glider

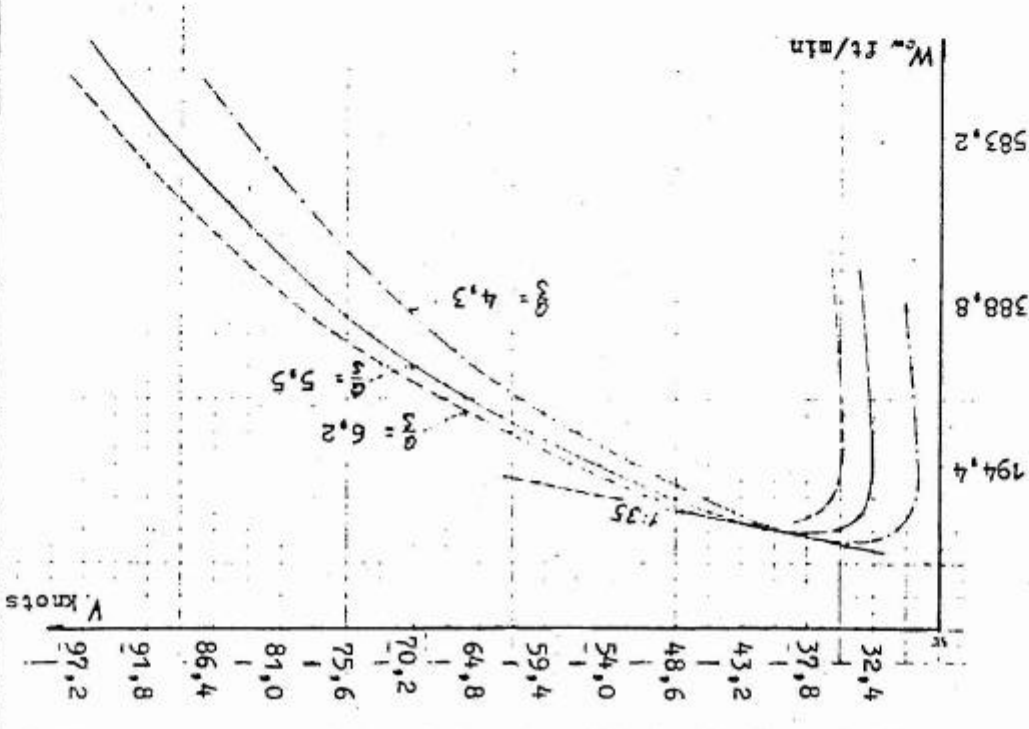

Fig. 4 Speed polar for SZD-51-1 glider

Fig. 5. Wing assembling

- 1 - Wing spar ends
- 2 - fuselage pivots
- 3 - spar pivots
- 4 - nests for pivots
- 5 - assembling lever
- 6 - spar feet
- 7 - bolt
- 8 - securing hole
- 9 - safety pin

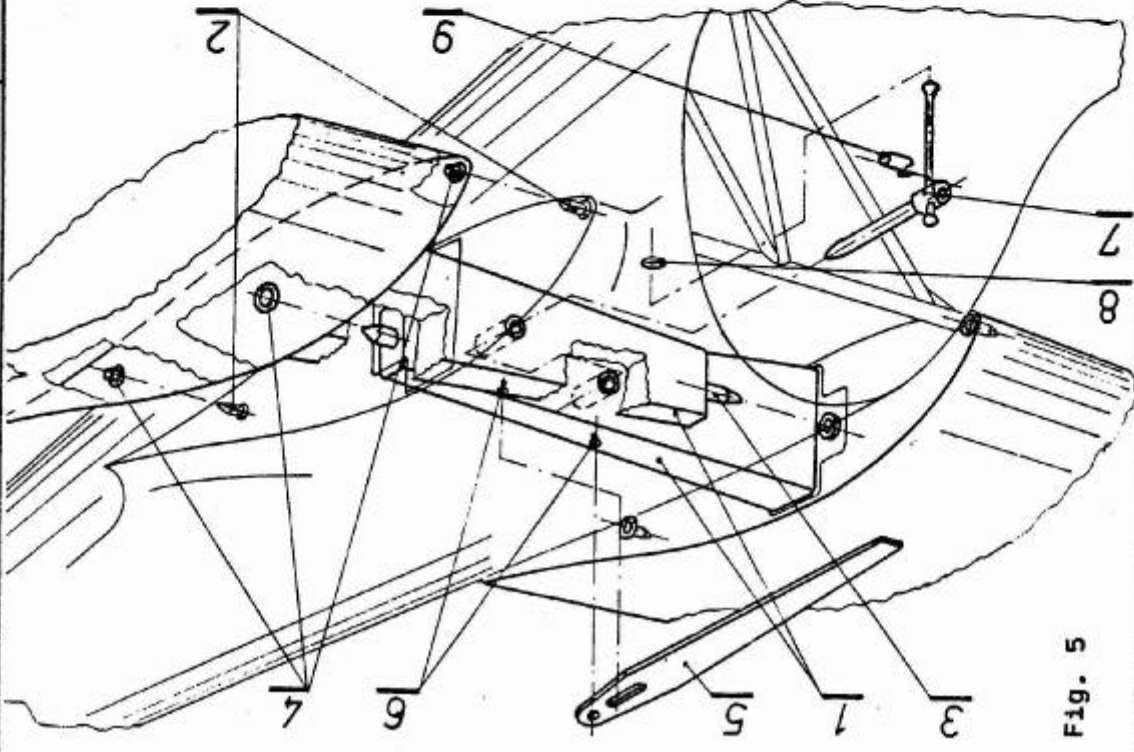

Fig. 5

Fig. 6. Horizontal tailplane assembling

- 1 - horizontal tailplane
- 2 - fin
- 3 - quick-locking push-rod end
- 4 - elevator lever
- 5 - bolt
- 6 - safety pin
- 7 - tailplane fitting screw

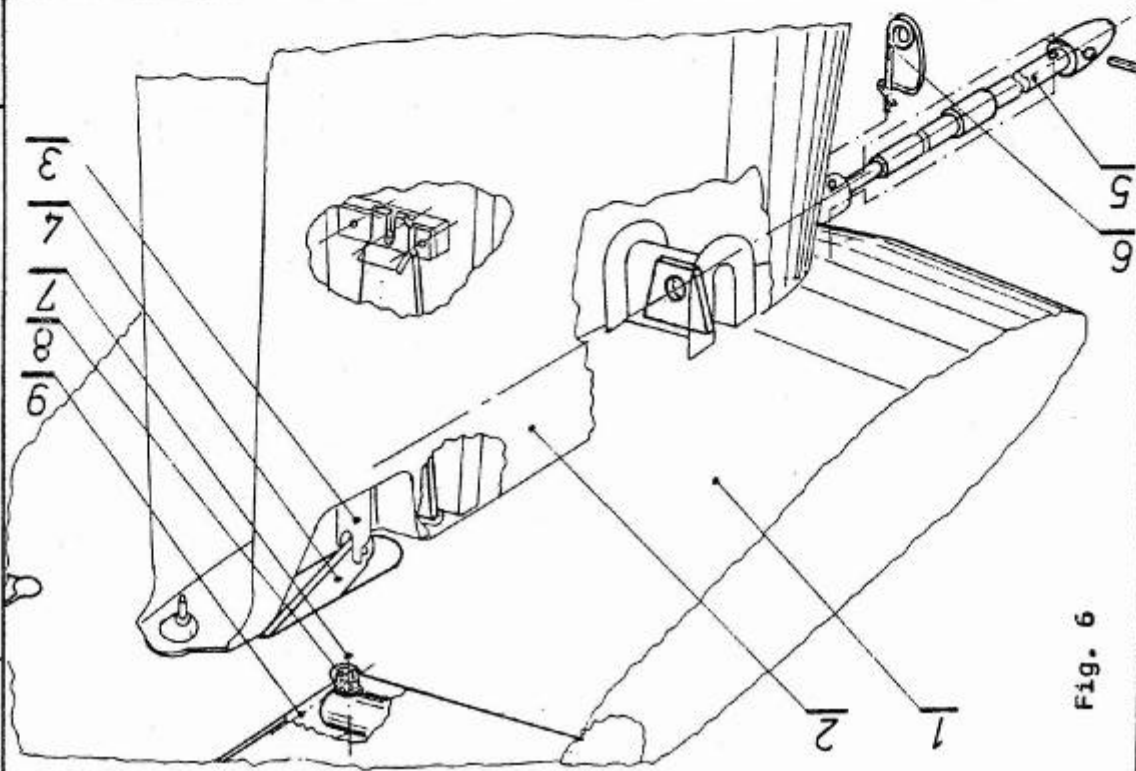

Fig. 6

Fig. 7. Colour marking of airspeed indicator dial

- colour
- red
 - yellow
 - green



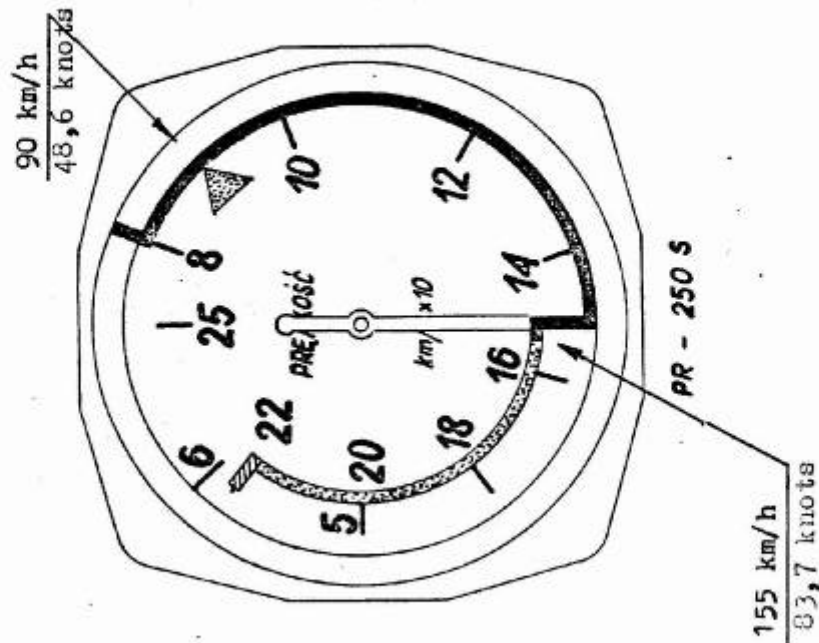

Fig. 7

Fig. 8. Adjusting of Pilot's Position by means of folded cushion

1. Pilot without the cushion /cushion stored behind the back-rest/.
2. Folded cushion on back-rest.
3. Thick part of cushion on the back-rest, thin part on the seat,
4. Thin part of cushion on the seat, thick part on the back-rest,
5. Thick part of cushion on the back-rest, thin part in the luggage compartment,
6. Thin part of cushion on the back-rest, thick part in the luggage compartment,

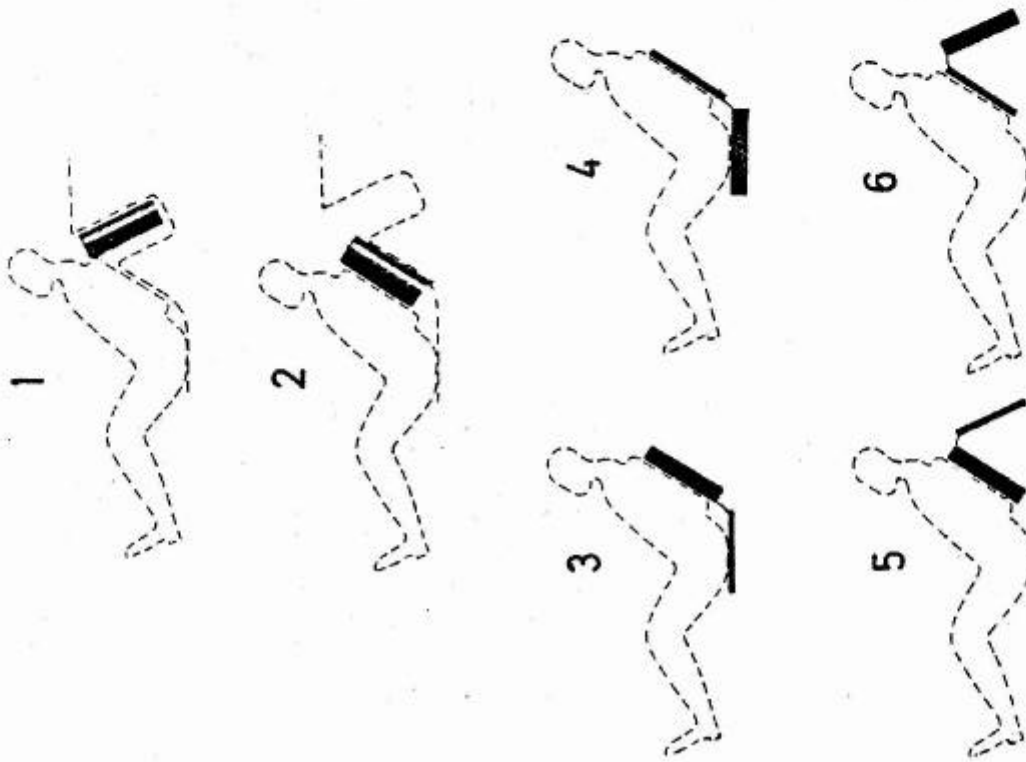

Fig. 8.

Fig. 9. Allowable range of empty glider c.g. locations in respect to root rib leading edge, X_{SC}

For details see Technical Service Manual - chapter 6.

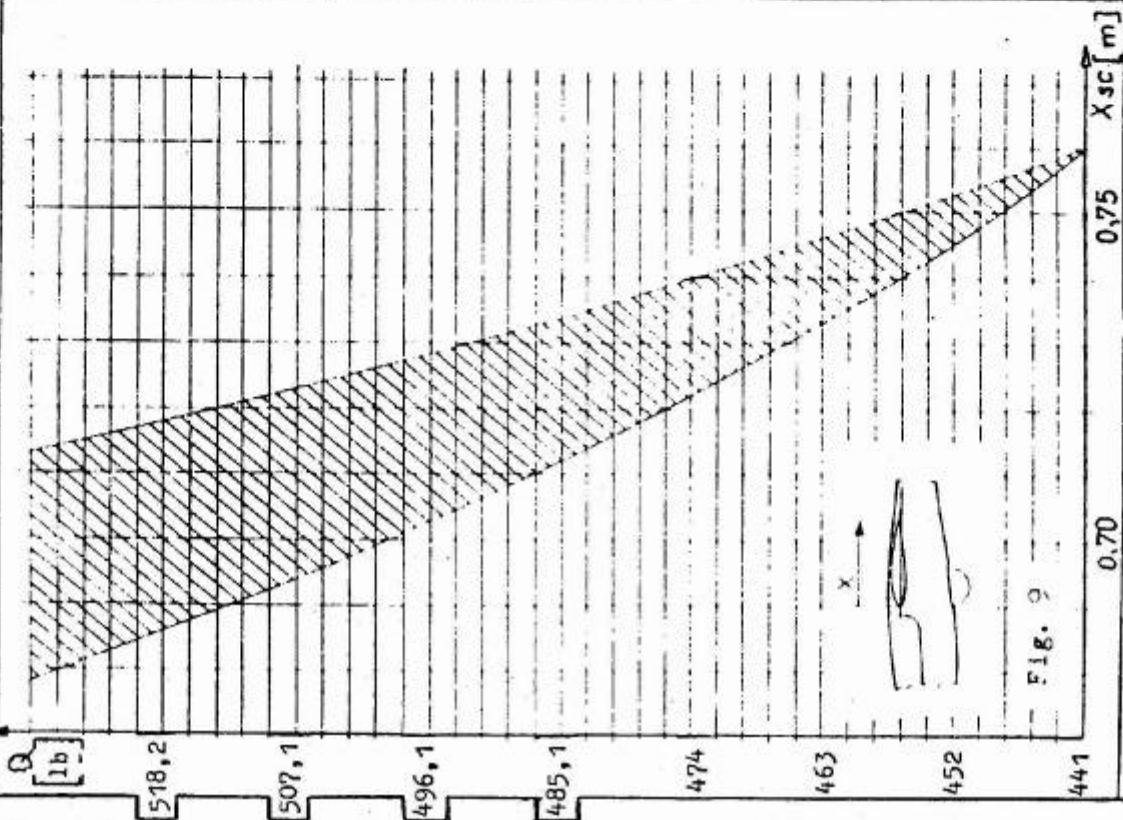

Fig. 10. Operation of trimming device

- 1 - press
- 2.- change the location
- 3 - release, check the locking

A - will be tail heavy

B - will be nose heavy

C - Flight direction

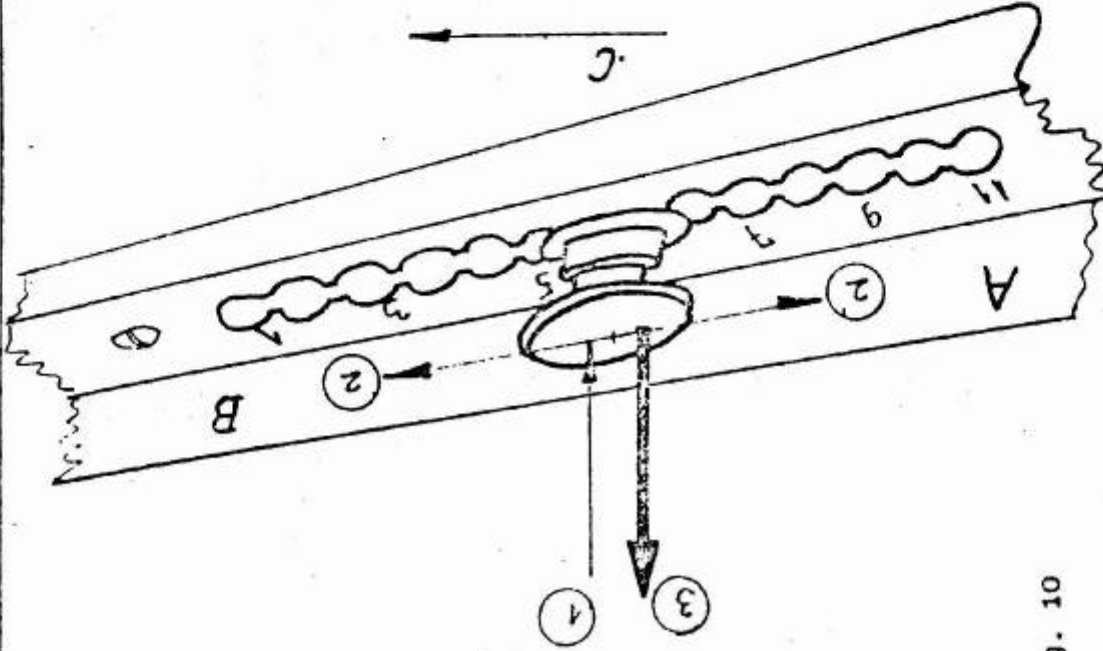

Fig. 10

7. PLACARDS

Placard No	Meaning	Page:	
1.	Air brake extended	52	
2.	Emergency canopy jettisoning		
3.	Trimming device		
4.	Releasing of towing cable		
5.	Pedal adjustment		
6.	Air conditioning of cockpit		
7.	Wheel brake		
8.	No smoking		
9.	Luggage compartment		
10.	Sanitary installation		
11.	Compass correction		
12.	Turn indicator switch on/off		
13.	Max. 22 lb		
14.	Soft luggage max. 11 lb		53
15.	Operation limitations		55
16.	Loading plan		55
17.	Factory identification placard		55
18.	Bottom hook without self-releasing		53
19.	Bottom hook with self-releasing		53
20.	Trimming device locations		53

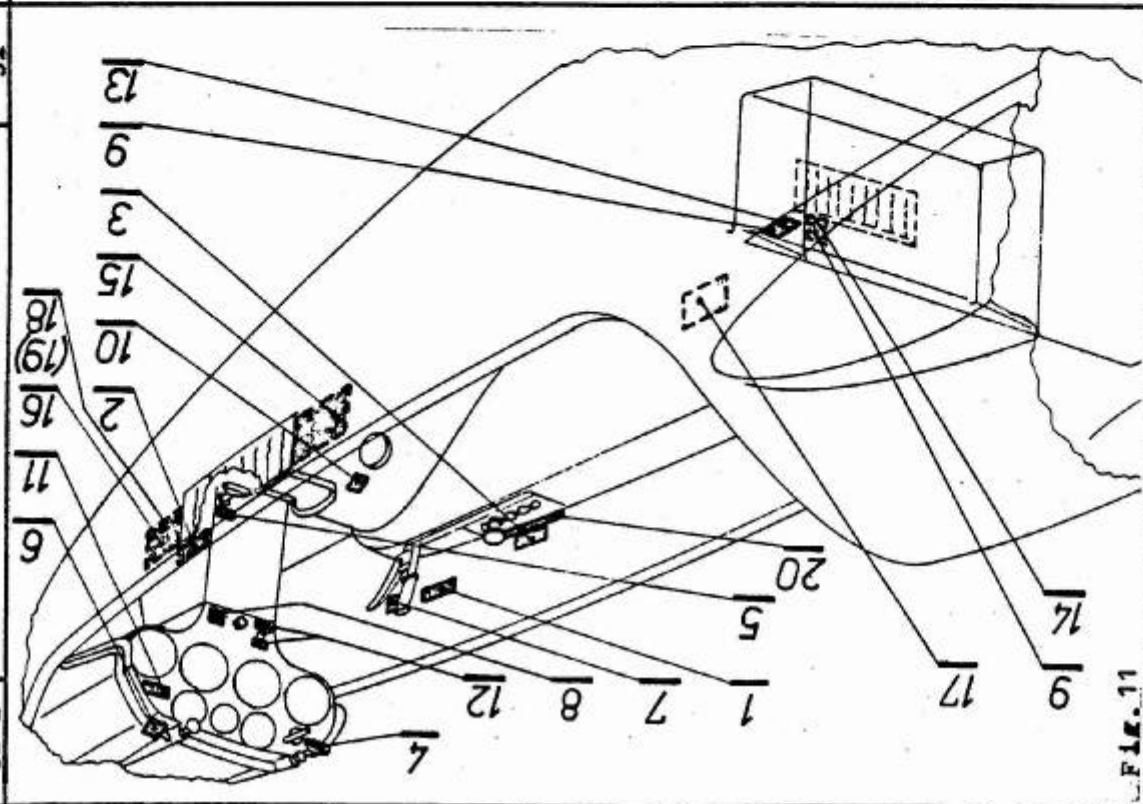
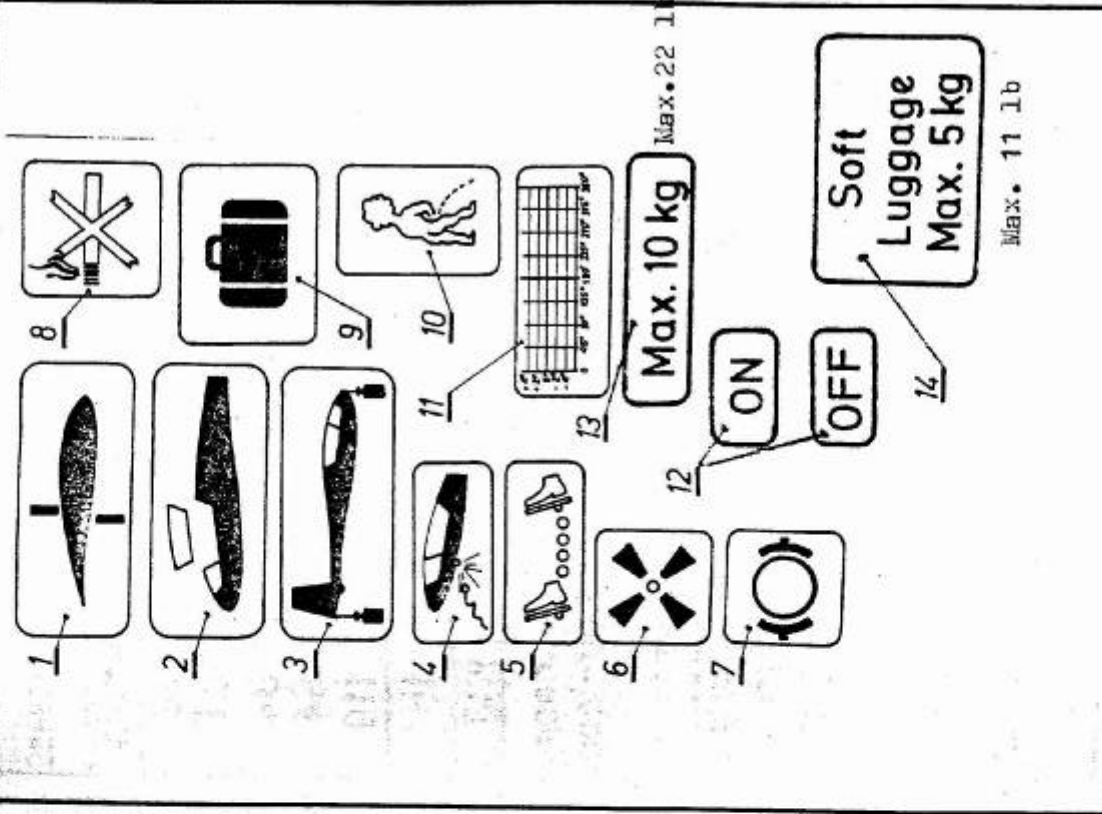

Fig. 11







Soft Luggage Max. 5 kg

Max. 11 lb

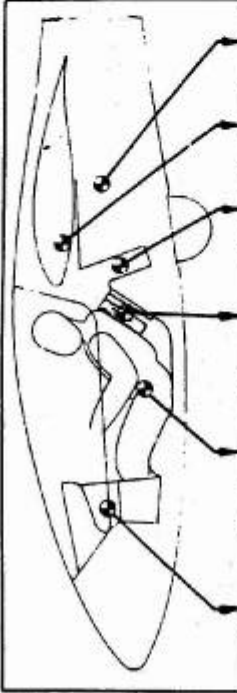
SZD-51-1	FLIGHT MANUAL	Page: 53
SZD-51-1 JUNIOR		
FLIGHT LIMITATIONS		
AIRSPEED	IAS	knots
V _W WINCH-LAUNCHING		70
V _T AERO-TOWING		81
V _A MANOEUVRING		84
V _B GUST CONDITIONS		84
V _{NE} DIVING		119
MASSES		lb
ALL-UP		838
AEROBATIC MANOEUVRES: looping stall turn, quick half-roll-half-loop, spiral, spinning		
BOTTOM HOOK WITHOUT SELF-RELEASING SZD-III A-56P		
BOTTOM HOOK WITH SELF-RELEASING TOST G73		
11 . 9 . 7 . 5 . 3 . 1		
20		
Issue I - Dec. 1984		

SZD-51-1	FLIGHT MANUAL	Page: 54
Description of loading plan		
B- balancing or additional equipment mass in instrument panel		
PILOT - mass of cockpit load		
PPPP - cushion under the back position:		
//	-	double folded
// - / - 0	-	arbitrary
0	-	no cushion
C- soft luggage in compartment behind the seat		
D- battery, barograph etc.		
E- oxygen bottle of 4 l capacity.		
N O T E S:		
1. The balancing mass B in instrument panel for pilot's mass lower than 125,7 lbs not obligatory, providing that the glider is equipped with RS-6101 transceiver, or TA-03 A oxygen equipment or additional equipment in instrument panel of mass above 2,2 lb		
2. If the oxygen bottle is installed in the fuselage central part framework/acc. to Annex No 2 to this Manual/ the maximum allowed mass of load B in instrument panel is 11 lb for the full range of pilot's mass up to 242,6 lb		
Issue I - Dec. 1984		



B		PILOT	PPPP	C	D	E			
lb	lb						lb	lb	lb
max	min	121	 // - / - O	 max 11	 max 22	 max 22			
11	1	123					11	22	22
10	0	125					11	22	22
9		128+236	O						
7.5		238							
		240							
		242							

PRZEDS. DOSWIADCZALNO
 PRODUKCYJNE SZYBON.
 PZL - BIELSKO

ODDZIAK
 MADE IN POLAND

NR ROZPOZN.

SERIA

NR FABR.

ROK BUD.

KONTROLA

The empty glider c.g. shall comply with the allowed range /Fig.9/. If not, the glider shall be balanced by means of installing the fixed balancing mass /acc. to Technical Service Manual item.6.1./

The final weighing results are written down by the factory. In case of repairs or changes of equipment the c.g. location shall be checked and if necessary, move it into the allowed range under supervision of Authority.

The weighing results shall be written down into the table on page 57.

SZD-51-1	FLIGHT MANUAL	Page: 57
Date of glider mass weigh- ing 09.12.1988 479,1	Empty glider mass 479,1	C.G. location cm 43,4
Additional balancing mass kg —	front — rear —	Perfor- med by: <i>Perds</i>
Author- ity:		

8. TABLE OF GLIDER WEIGHING

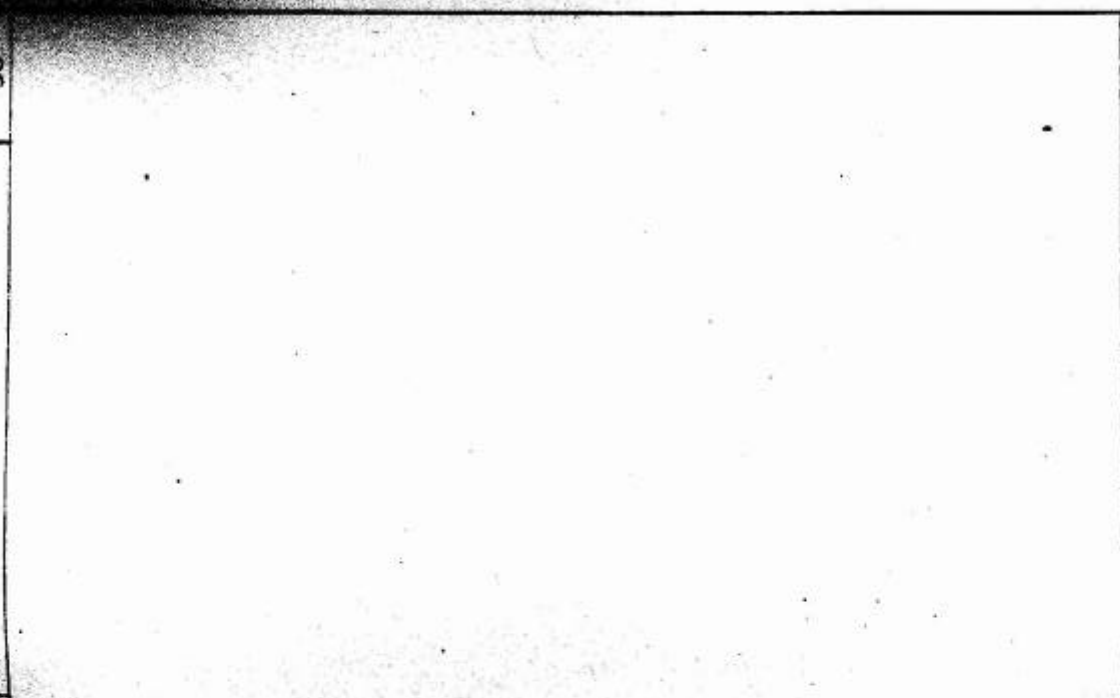
-1	FLIGHT MANUAL	Page: 58
		

PROTOCOL

OF SAILPLANE WEIGHING AND DETERMINING CENTER OF GRAVITY POSITION

Annex to Building Inspection Certificate
S2D-51-1
factory No B-1840

••

I. Weighing of sailplane

Wing left 55,3 kg

Wing right 55,7 kg

Elevator unit 10,1 kg

Rudder 3,7 kg

Fuselage with complete equipment 92,5 kg

..... kg

..... kg

..... kg

Weight empty

..... 217,3 kg

Permissible empty weight

..... 240,0 kg

II. Center of Gravity (sailplane in horizontal flight position)

1/ distribution of weight-empty: —

P_A - front support 191,8 kg

P_B - rear support 25,5 kg

2/ distances:

l - between supports 370,0 cm

a - from front support P_A to wing leading edge (rib of the fuselage) 30,0 cm

c.g. - Empty sailplane center of gravity position on the root rib profile chord at fuselage 73,4 cm

to - Extreme permissible center of gravity position 71,7 cm

from - 73,7 cm

Worked out by:

(Signature)

(Signature)

9.11.1988

(Date)

Przedsiębiorstwo
"PZL-BIELKO"
Borowidzka 10, 250-21, Bielko, 25

42-200 Bielko-Bialo, ul. Chłopska 25
tel. 250-21, telex 21759

Identyfikator 0036921

-2-